

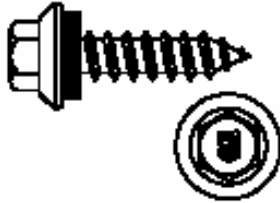





Metal Roofing and Siding Accessories

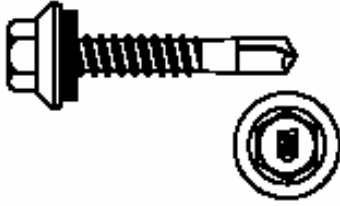

<p>MATCHING FINISH SELF-TAPPING FASTENERS w/ FLAT TOP UNDERCUT HEAD w/ EPDM SEALING WASHER This fastener will not drill</p>  <p>Holes must be pre-drilled through all metal when using this type of fastener.</p>	<table border="1"> <thead> <tr> <th>SIZE</th> <th>LENGTH</th> <th>THREAD</th> <th>HEAD AF</th> <th>WT./M.</th> </tr> </thead> <tbody> <tr> <td>#14</td> <td>¾"</td> <td>"A"</td> <td>⅝"</td> <td>14.9#</td> </tr> <tr> <td>#14</td> <td>1"</td> <td>"A"</td> <td>⅝"</td> <td>16.5#</td> </tr> <tr> <td>#14</td> <td>1½"</td> <td>"A"</td> <td>⅝"</td> <td>21.2#</td> </tr> <tr> <td>#14</td> <td>2"</td> <td>"A"</td> <td>⅝"</td> <td>26.3#</td> </tr> <tr> <td>#17</td> <td>1"</td> <td>"AB"</td> <td>⅝"</td> <td>17.8#</td> </tr> </tbody> </table>	SIZE	LENGTH	THREAD	HEAD AF	WT./M.	#14	¾"	"A"	⅝"	14.9#	#14	1"	"A"	⅝"	16.5#	#14	1½"	"A"	⅝"	21.2#	#14	2"	"A"	⅝"	26.3#	#17	1"	"AB"	⅝"	17.8#					
SIZE	LENGTH	THREAD	HEAD AF	WT./M.																																
#14	¾"	"A"	⅝"	14.9#																																
#14	1"	"A"	⅝"	16.5#																																
#14	1½"	"A"	⅝"	21.2#																																
#14	2"	"A"	⅝"	26.3#																																
#17	1"	"AB"	⅝"	17.8#																																
<p>MATCHING FINISH SELF-TAPPING FASTENERS w/ DISH-BONDED, ONE-PIECE SEALING WASHER This fastener will not drill</p>  <p>Holes must be pre-drilled through all metal when using this type of fastener.</p>	<table border="1"> <thead> <tr> <th>SIZE</th> <th>LENGTH</th> <th>THREAD</th> <th>HEAD AF</th> <th>WT./M.</th> </tr> </thead> <tbody> <tr> <td>#14</td> <td>3" *</td> <td>"A"</td> <td>⅝"</td> <td>34.2#</td> </tr> <tr> <td>#14</td> <td>4" **</td> <td>"A"</td> <td>⅝"</td> <td>41.9#</td> </tr> </tbody> </table> <p>* Stocked in colors to match GALVALUME® and "Polar White" only. Other colors must be special ordered.</p> <p>** Stocked in color to match GALVALUME® only. Other colors must be special ordered.</p>	SIZE	LENGTH	THREAD	HEAD AF	WT./M.	#14	3" *	"A"	⅝"	34.2#	#14	4" **	"A"	⅝"	41.9#																				
SIZE	LENGTH	THREAD	HEAD AF	WT./M.																																
#14	3" *	"A"	⅝"	34.2#																																
#14	4" **	"A"	⅝"	41.9#																																
<p>300 SERIES STAINLESS STEEL SELF-TAPPING FASTENERS w/ DISH-BONDED, ONE-PIECE SEALING WASHER This fastener will not drill</p>  <p>Holes must be pre-drilled through all metal when using this type of fastener. Caution! The threads on stainless fasteners are softer than carbon steel and will strip out if over-torqued or forced into too small a hole.</p>	<table border="1"> <thead> <tr> <th>SIZE</th> <th>LENGTH</th> <th>THREAD</th> <th>HEAD AF</th> <th>WT./M.</th> </tr> </thead> <tbody> <tr> <td>#14</td> <td>¾"</td> <td>"A"</td> <td>⅝"</td> <td>14.3#</td> </tr> <tr> <td>#14</td> <td>1"</td> <td>"A"</td> <td>⅝"</td> <td>16.2#</td> </tr> <tr> <td>#14</td> <td>1½"</td> <td>"A"</td> <td>⅝"</td> <td>21.6#</td> </tr> <tr> <td>#14</td> <td>2"</td> <td>"A"</td> <td>⅝"</td> <td>26.0#</td> </tr> <tr> <td>#14</td> <td>3"</td> <td>"A"</td> <td>⅝"</td> <td>34.1#</td> </tr> <tr> <td>#17</td> <td>1"</td> <td>"AB"</td> <td>⅝"</td> <td>19.5#</td> </tr> </tbody> </table> <p>Most lengths and colors are special order and could be subject to limited availability. Please inquire.</p>	SIZE	LENGTH	THREAD	HEAD AF	WT./M.	#14	¾"	"A"	⅝"	14.3#	#14	1"	"A"	⅝"	16.2#	#14	1½"	"A"	⅝"	21.6#	#14	2"	"A"	⅝"	26.0#	#14	3"	"A"	⅝"	34.1#	#17	1"	"AB"	⅝"	19.5#
SIZE	LENGTH	THREAD	HEAD AF	WT./M.																																
#14	¾"	"A"	⅝"	14.3#																																
#14	1"	"A"	⅝"	16.2#																																
#14	1½"	"A"	⅝"	21.6#																																
#14	2"	"A"	⅝"	26.0#																																
#14	3"	"A"	⅝"	34.1#																																
#17	1"	"AB"	⅝"	19.5#																																

Metal Roofing and Siding Accessories

MATCHING FINISH SELF-DRILLING FASTENERS w/ FLAT TOP UNDERCUT HEAD w/ EPDM SEALING WASHER	SIZE	LENGTH	HEAD AF	WT./M.
	#12	1¼"	⅝"	21.0#
	#12	1½"	⅝"	23.1#
	#12	2"	⅝"	28.0#
	#14	⅞" Lap-Tek	⅝"	16.0#
<p>Use Lap-Tek as a sheet metal to sheet metal fastener only. Use these fasteners only when attaching sheet metal directly to steel Zees and Cees. These fasteners are not made for attachment into wood members or decking.</p>	<p>Most lengths and colors except 1¼" and ⅞" Lap-Tek are special order and could be subject to limited availability. Please inquire.</p>			

MATCHING FINISH STAINLESS STEEL POP RIVETS	SIZE	GRIP RANGE	WT./M.
	⅜" Diameter	.063" - .125"	2.8#
Body and mandrel are stainless steel.			
DRILL BITS	SIZE	DIA.	USED FOR
	⅜"	(.125")	Pop rivets, pilot holes for #14 stitch
	#8	(.199")	#14 members/stitch
	⅞ ₃₂ "	(.219")	#14 stainless steel members/stitch
	#1	(.228")	#14 into heavy structural
MAGNETIC SOCKET (HEX DRIVE)	SIZE	USED FOR	
	⅜"	#14 driller or tapper	
	⅝"	#12 driller	
	¼"	#10 wood fastener	

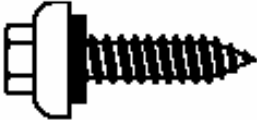
Metal Roofing and Siding Accessories

<p>MATCHING FINISH LONG-LIFE ZINC-ALUMINUM HEAD SELF-TAPPING FASTENERS w/ SEALING WASHERS</p> <p>ATLAS ULTIMATE™</p> <p>This fastener will not drill</p>  <p>Holes must be pre-drilled through all metal when using this type of fastener.</p>	<table border="1"> <thead> <tr> <th>SIZE</th> <th>LENGTH</th> <th>THREAD</th> <th>HEAD AF</th> <th>WT./M.</th> </tr> </thead> <tbody> <tr> <td>#14</td> <td>¾"</td> <td>"AB"</td> <td>⅝"</td> <td>15.4#</td> </tr> <tr> <td>#14</td> <td>1"</td> <td>"AB"</td> <td>⅝"</td> <td>18.5#</td> </tr> <tr> <td>#14</td> <td>1½"</td> <td>"AB"</td> <td>⅝"</td> <td>22.7#</td> </tr> <tr> <td>#14</td> <td>2"</td> <td>"AB"</td> <td>⅝"</td> <td>24.5#</td> </tr> <tr> <td>#17</td> <td>1"</td> <td>"AB"</td> <td>⅝"</td> <td>25.8#</td> </tr> </tbody> </table> <p>Many lengths and colors are special order and could be subject to limited availability. Please inquire.</p>	SIZE	LENGTH	THREAD	HEAD AF	WT./M.	#14	¾"	"AB"	⅝"	15.4#	#14	1"	"AB"	⅝"	18.5#	#14	1½"	"AB"	⅝"	22.7#	#14	2"	"AB"	⅝"	24.5#	#17	1"	"AB"	⅝"	25.8#
SIZE	LENGTH	THREAD	HEAD AF	WT./M.																											
#14	¾"	"AB"	⅝"	15.4#																											
#14	1"	"AB"	⅝"	18.5#																											
#14	1½"	"AB"	⅝"	22.7#																											
#14	2"	"AB"	⅝"	24.5#																											
#17	1"	"AB"	⅝"	25.8#																											
<p>MATCHING FINISH LONG-LIFE ZINC-ALUMINUM HEAD SELF-DRILLING FASTENERS w/ SEALING WASHERS</p> <p>ATLAS ULTIMATE™</p>  <p>Use #12 fasteners only when attaching sheet metal directly to steel Zees and Cees. #12 fasteners are not made for attachment into wood members or decking. Use #14 fasteners as a sheet metal to sheet metal fastener only.</p>	<table border="1"> <thead> <tr> <th>SIZE</th> <th>LENGTH</th> <th>HEAD AF</th> <th>WT./M.</th> </tr> </thead> <tbody> <tr> <td>#12</td> <td>1¼"</td> <td>⅝"</td> <td>16.1#</td> </tr> <tr> <td>#12</td> <td>1½"</td> <td>⅝"</td> <td>19.2#</td> </tr> <tr> <td>#12</td> <td>2"</td> <td>⅝"</td> <td>20.7#</td> </tr> <tr> <td>#14</td> <td>⅞" Lap-Tek</td> <td>⅝"</td> <td>18.0#</td> </tr> </tbody> </table> <p>Many lengths and colors are special order and could be subject to limited availability. Please inquire.</p>	SIZE	LENGTH	HEAD AF	WT./M.	#12	1¼"	⅝"	16.1#	#12	1½"	⅝"	19.2#	#12	2"	⅝"	20.7#	#14	⅞" Lap-Tek	⅝"	18.0#										
SIZE	LENGTH	HEAD AF	WT./M.																												
#12	1¼"	⅝"	16.1#																												
#12	1½"	⅝"	19.2#																												
#12	2"	⅝"	20.7#																												
#14	⅞" Lap-Tek	⅝"	18.0#																												
<p>MATCHING FINISH WOOD FASTENERS w/ DISH-BONDED ONE-PIECE SEALING WASHERS</p> <p>ATLAS WOODTITE</p>  <p>These fasteners will punch through 26ga. sheet metal and fasten into wood members or deck only.</p>	<table border="1"> <thead> <tr> <th>SIZE</th> <th>LENGTH</th> <th>HEAD AF</th> <th>WT./M.</th> </tr> </thead> <tbody> <tr> <td>#9</td> <td>1"</td> <td>¼"</td> <td>8.7#</td> </tr> <tr> <td>#9</td> <td>1½"</td> <td>¼"</td> <td>10.8#</td> </tr> <tr> <td>#9 *</td> <td>2"</td> <td>¼"</td> <td>13.1#</td> </tr> <tr> <td>#9 *</td> <td>3"</td> <td>¼"</td> <td>17.7#</td> </tr> </tbody> </table> <p>* Many lengths and colors are special order and could be subject to limited availability. Please inquire.</p>	SIZE	LENGTH	HEAD AF	WT./M.	#9	1"	¼"	8.7#	#9	1½"	¼"	10.8#	#9 *	2"	¼"	13.1#	#9 *	3"	¼"	17.7#										
SIZE	LENGTH	HEAD AF	WT./M.																												
#9	1"	¼"	8.7#																												
#9	1½"	¼"	10.8#																												
#9 *	2"	¼"	13.1#																												
#9 *	3"	¼"	17.7#																												

Metal Roofing and Siding Accessories

MATCHING FINISH LONG-LIFE
ZINC-ALUMINUM HEAD WOOD
FASTENERS w/ SEALING WASHERS

 WOODMATE™





These fasteners will punch through 26ga. sheet metal and fasten into wood members or deck only.

SIZE	LENGTH	HEAD AF	WT./M.
#10	1"	5/16"	14.2#
#10	1½"	5/16"	16.3#
#10	2"	5/16"	18.6#

All lengths and colors are special order and could be subject to limited availability. Please inquire.

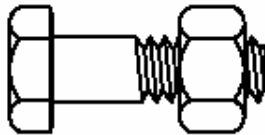
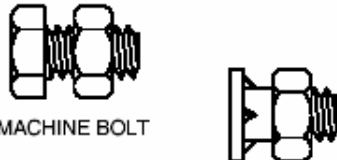
Metal Roofing and Siding Accessories

A325 HIGH STRENGTH STRUCTURAL BOLTS WITH NUTS	DIAMETER	LENGTH	THREAD	TPI	WT./100
 <p>All bolts have Heavy Hex Heads. All nuts are A194 Heavy Hex Nuts.</p>	1/2"	x 1 1/4"	1"	13	17.8#
	1/2"	x 1 1/2"	1"	13	19.2#
	5/8"	x 1 1/2"	1 1/4"	11	33.1#
	5/8"	x 1 3/4"	1 1/4"	11	35.3#
	5/8"	x 2"	1 1/4"	11	37.4#
	3/4"	x 1 1/2"	1 3/8"	10	55.3#
	3/4"	x 2"	1 3/8"	10	58.4#
	3/4"	x 2 1/4"	1 3/8"	10	61.6#
	3/4"	x 2 1/2"	1 3/8"	10	64.7#
	3/4"	x 2 3/4"	1 3/8"	10	67.8#
	1"	x 2 3/4"	1 3/4"	8	135.0#
	1"	x 3"	1 3/4"	8	141.0#
	1"	x 3 1/4"	1 3/4"	8	146.0#
A307 LOW CARBON BOLTS w/ NUTS	DIAMETER	LENGTH	THREAD	TPI	WT./100
 <p>MACHINE BOLT</p> <p>FIN NECK BOLT</p>	1/2"	x 1 1/4"	1 1/4"	13	10.3#
	1/2"	x 1 1/4"	1 1/8"	13	8.5#
(fin neck, flat head)					
USS FLAT WASHERS	BOLT DIAMETER	I.D.	O.D.	WT./100	
 <p>(Not Hardened)</p>	1/2"	x 5/16"	1 3/8"	3.9#	
	5/8"	x 1 1/8"	1 1/4"	7.7#	
	3/4"	x 1 3/16"	2"	11.0#	
	1"	x 1 1/8"	2 1/2"	18.9#	
A307 LOW CARBON HEX NUTS	BOLT DIAMETER	THICKNESS	TPI	WT./100	
	1/2"	x 5/16"	13	3.8#	
	5/8"	x 3/8"	11	7.3#	
	3/4"	x 27/64"	10	11.9#	
	1"	x 35/64"	8	28.3#	

Metal Roofing and Siding Accessories

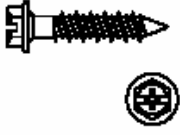
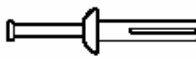
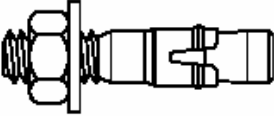
<p>THREADED MASONRY FASTENERS CARBON STEEL OXYSEAL III® w/ PHILLIPS HEAD/HEX WASHER HEAD  CON-MATE®</p>  <p>For fastening angles or panel support trim to concrete foundation.</p>	<table border="1"> <thead> <tr> <th>SIZE</th> <th>LENGTH</th> <th>HEAD AF</th> <th>WT./M.</th> <th>PRICE PER 1000</th> </tr> </thead> <tbody> <tr> <td>¼ - 14</td> <td>1¼"</td> <td>¾"</td> <td>14.3#</td> <td>107.50</td> </tr> </tbody> </table>	SIZE	LENGTH	HEAD AF	WT./M.	PRICE PER 1000	¼ - 14	1¼"	¾"	14.3#	107.50															
SIZE	LENGTH	HEAD AF	WT./M.	PRICE PER 1000																						
¼ - 14	1¼"	¾"	14.3#	107.50																						
<p>NAIL-IN CINCH ANCHOR</p>  <p>For fastening angles or panel support trim to concrete foundation.</p>	<table border="1"> <thead> <tr> <th>DIAMETER</th> <th>LENGTH</th> <th>WT./100</th> <th>PRICE PER 100</th> </tr> </thead> <tbody> <tr> <td>¼"</td> <td>1¼"</td> <td>2.1#</td> <td>23.50</td> </tr> </tbody> </table> <p>Use ¼" diameter masonry drill bit to drill hole in concrete.</p>	DIAMETER	LENGTH	WT./100	PRICE PER 100	¼"	1¼"	2.1#	23.50																	
DIAMETER	LENGTH	WT./100	PRICE PER 100																							
¼"	1¼"	2.1#	23.50																							
<p>WEDGE ANCHOR w/ NUT AND FLAT WASHER</p> 	<table border="1"> <thead> <tr> <th>DIAMETER</th> <th>LENGTH</th> <th>THREAD</th> <th>WT./100</th> <th>PRICE PER 100</th> </tr> </thead> <tbody> <tr> <td>½"</td> <td>2¾"</td> <td>1½"</td> <td>23.0#</td> <td>87.00</td> </tr> <tr> <td>⅝"</td> <td>4¼"</td> <td>1¾"</td> <td>53.0#</td> <td>186.00</td> </tr> <tr> <td>¾"</td> <td>5½"</td> <td>2"</td> <td>90.0#</td> <td>300.00</td> </tr> <tr> <td>1"</td> <td>6"</td> <td>2½"</td> <td>240.0#</td> <td>1165.00</td> </tr> </tbody> </table> <p>All wedge anchors are zinc-plated. Use same diameter masonry drill bit to drill hole in concrete.</p>	DIAMETER	LENGTH	THREAD	WT./100	PRICE PER 100	½"	2¾"	1½"	23.0#	87.00	⅝"	4¼"	1¾"	53.0#	186.00	¾"	5½"	2"	90.0#	300.00	1"	6"	2½"	240.0#	1165.00
DIAMETER	LENGTH	THREAD	WT./100	PRICE PER 100																						
½"	2¾"	1½"	23.0#	87.00																						
⅝"	4¼"	1¾"	53.0#	186.00																						
¾"	5½"	2"	90.0#	300.00																						
1"	6"	2½"	240.0#	1165.00																						